

The glory days of laryngology

Ashraf A. Yakoot

Department of Otolaryngology, Armed Forces Hospital, Cairo, Egypt

Egypt J Otolaryngol 29:224–228
© 2013 The Egyptian Oto - Rhino - Laryngological Society
1012-5574

Correspondence to Ashraf A. Yakoot, MD, Department of Otolaryngology, Armed Forces Hospital, 107 Gendy St Hadayq Koba, Cairo, Egypt
Tel: +002022662318; fax: +01001475631;
e-mail: drashraf2007@hotmail.com

Received 3 April 2013

Accepted 2 May 2013

The Egyptian Journal of Otolaryngology

2013, 29:224–228

The oldest reference in laryngology is a drawing found in medical tombs in the planes of Saqqara, Egypt, from ~3600 years BC. The image seems to depict a tracheostomy.

Aristotle was the first to mention the larynx in his book *Historia animalium*, 350 BC, in which he described the larynx, observing that speech and breathing occur through it, which is protected by a structure known as the windmill.

Historians reported a tracheostomy performed by Alexander the Great himself, who saved the life of an agonizing soldier by sticking the tip of his spear in the region described as the windmill by Aristotle, probably the cricoid cartilage.



The first ever reported use of an experimental detailed surgery (tracheostomy) model was made by the Arabic scientist Ibn Zuhr (1091–1161) in his book *Al-tasrif liman ajaz al-taelif*; he greatly influenced the medical knowledge for several centuries in both the east and the west.

Ibn Zuhr

Great Physician
(1091-1161)



Ferrein, in 1741, was the first to publish the term vocal cords, compared with the cords of a violin.



One century afterward, a physiologist Johannes Muller analyzed the movement of vocal cords in cadavers.

The barrier to the advancement of laryngology was the incapacity to directly examine the larynx. These early pioneers even risked experimentation on their own larynxes to determine how to adapt endoscopy to this field. The work demanded a lot of caution during these early days, as one small move in the wrong direction could easily spell disaster.

Manuel Garcia, 1854, a Spanish Music Professor, with a small mirror, used by dentists and proper lighting, could see the functioning of his own vocal cords with breathing and vocalization. He published numerous books about voice and developed his own laryngoscopic technique.



Introduced in 1743, Levet's angled-mirror instrument for viewing the larynx indirectly apparently did enable practitioners to visualize the larynx in his patients using sunlight, only during spring and summer in Europe.

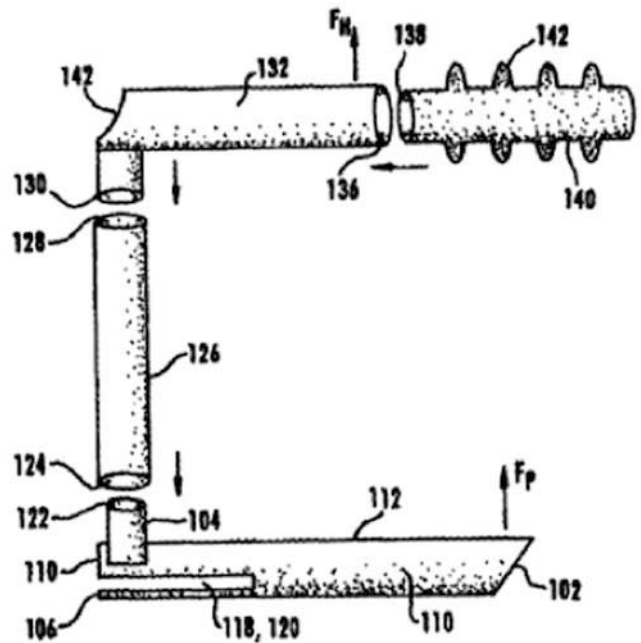
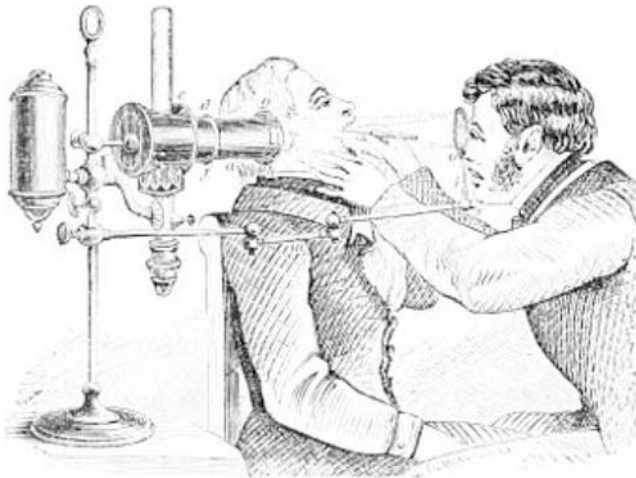

Attempts at laryngoscopy were made using a device called Avery's laryngoscope, but ineffectively.

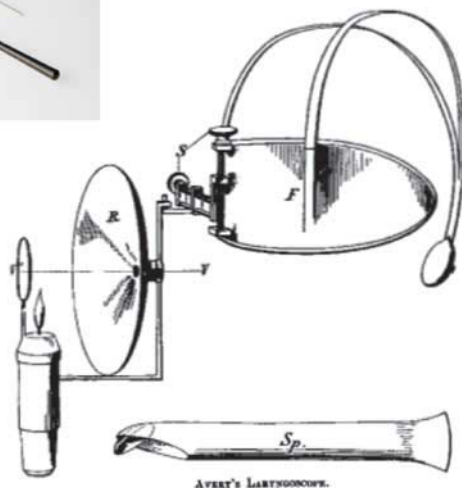

Babington's 'glottoscope', presented in 1829, was unique in that it was the first instrument to combine the previously separate devices of a reflecting mirror and a tongue depressor into one clinically practical unit.

Schnitzler, in 1895, created an impressive atlas of laryngology, which is used to date in the University of Vienna.

Czermak stands out especially for one of the most significant achievements in endoscopic history by becoming the first ever to take a photograph. The photographic method itself was referred to as stereoscopy, which consisted of a box that housed a system of several lenses. The images were captured using metal plates coated with silver nitrate. Amazingly, all of this was achieved using only magnified candlelight as the light source.



One of the most notable difficulties was illumination during endoscopy; many physician-inventors attempted and failed to find a solution to this obstacle.

Early 19th-century laryngoscopists devised some of the most advanced and elaborate magnifying lamps for amplifying light.

Electricity would be the driving force behind endoscopic innovations and the decisive factor in overcoming the obstacle of poor visualization and illumination.

Mikulicz and Leiter were among the first to combine three of the most important elements that define endoscopy, the unification of an electric light source, an optical system, and a viewing tube, into one device with proven clinical success. As a result of such major innovations, Mikulicz is considered one of the most significant pioneers and founding fathers of endoscopy.

For the next 70 years, only the most skilled virtuosos could actually wield a rigid or a semiflexible laryngoscope successfully.

Gustav Killian, in Berlin, also developed a device for laryngoscopy and a device for holding a laryngoscope.

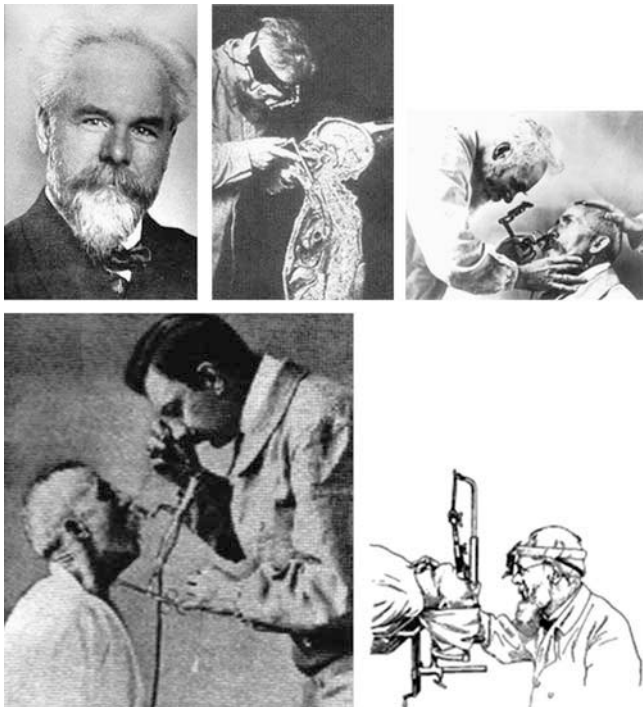

One of the most curious facts in the history of laryngectomies was the illness of Prince Frederick III, from Germany, who had dysphonia. In January 1887, Morrell Mackenzie, the most renowned otorhinolaryngologist of England, identified a hyperemic node in the left vocal fold during laryngoscopy and decided to perform an operation on the prince, under anesthesia by chloroform, removing part of the tumor through laryngoscopy, after many failed trials by German doctors. Two solutions were offered: total laryngectomy, which was extremely risky, or a palliative tracheostomy. The prince chose the second alternative. Bramann, a specialist in tracheotomies in children with diphtheria, performed the tracheostomy in January 1888; one day, during a coughing spell, the Emperor coughed his own trachea through the orifice and died 93 days later.



Laryngology was practiced by clinicians – not physicians – who prescribed treatments for acute laryngitis with the inhalation of benzoin vapors, and tolu balsam, and also formulations used to prepare singers before concerts, such as coca leaf tea.

The first total laryngectomy was carried out in 1873, in Vienna, by a surgeon, Theodor Billroth. The 35-year-old patient survived the procedure and lived for 7 more months. The major complication reported by Billroth in this patient was aspiration and difficulties in swallowing. Gluck, Billroth's student, solved this problem by performing a surgical technique in which he separated the larynx from the trachea, opening the neck's skin, and suturing the trachea orifice directly on this opening. Gluck also had knowledge on the removal of lymph node cells with metastatic involvement during the surgery to remove the primary tumor; he obtained the best results.

In 1900, Nicholas Taptas, a Turkish doctor, rehabilitated a laryngectomized patient using a connection between the trachea and a pharyngeal fistula that was created.

Sir Felix Semon, London, 1906, was the first laryngologist in his time to perform laryngeal fissure surgeries for laryngeal cancer in the initial stages.

Brunings, in Germany, and Jackson, in the USA, started using monocular microscopes to perform larynx surgeries during the 1950s. With the invention and widespread use of binocular microscopes, new surgical techniques for laryngeal procedures were introduced with the use of Yankauer's laryngoscopes, which used binocular magnifications and which were redesigned by Jako in 1970.

Historical attempts at airway stenting began in the 19th century, and tracheostomy tubes and Montgomery tracheal T tubes were used extensively for palliation of benign and malignant strictures.

Nuclear technology also led to progress in the medical field, especially with radiotherapy for the treatment of malignant lesions in the larynx.

Optic flexible fiber endoscopes were developed in 1954, by Hopkins, and led to a new era in endoscopy. Hence, in the last 30 years, laryngology has evolved gradually with the collaboration of head and neck surgeons, radiotherapists, oncologists, and other specialists.

The concept of phonosurgery, as a procedure to improve or re-establish voice, introduced by Von Leden, was restricted to laryngeal microsurgery; with more sophisticated microsurgery material and with better physiopathological material, endolaryngeal microsurgery has become more efficient.



The CO₂ laser was introduced in surgery in the 1970s by Polanyi, Strong and others. They coupled the CO₂ laser to the surgical microscope, thereby creating a new means of precise hemostatic dissection. Since their introduction in laryngology over 30 years ago, lasers have facilitated

critically important innovations. These advances have accommodated well to our specialty, which has led to the design of minimally invasive surgical approaches since mirror-guided interventions in the 19th century.

The growing sophistication and evolution of endoscopes, with modern optic fibers, combined with more sensitive stroboscopes, have led to a greater understanding of how the vocal cords work and a new era in laryngology: voice quality analysis.

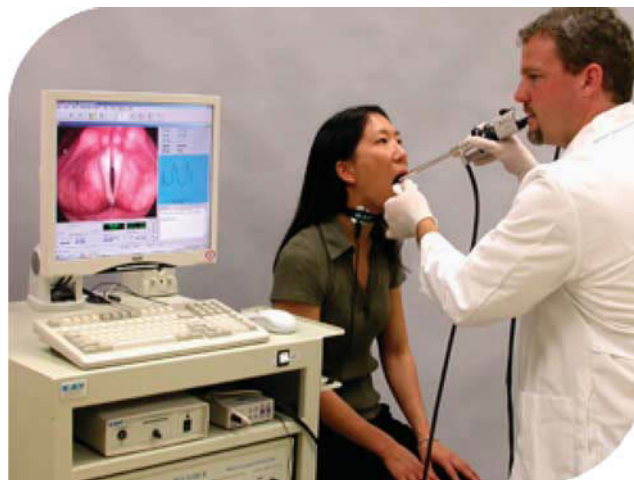

In 1998, the first larynx transplant was carried out in Cleveland; however, there were numerous problems, especially related to organ rejection by the patient's immune system.

Summary

Laryngoscopy by means of a simple dental mirror, which surely had aspired to be so much more, finally transformed into a true endoscopic superstar: fully loaded, with advanced optics, distal light, and capable of diagnostic and therapeutic procedures once considered impossible.

The field of laryngology gained considerable momentum toward the end of the 19th century and charged forward into the 20th century with whistles and bells and high hopes.

The concert of the birth of our modern laryngology is fascinating, and the tale of the invention of the laryngoscope shows how an idea that is floating in the atmosphere may suddenly crystallize in some wholly unexpected spot.

Acknowledgements

Conflicts of interest

There are no conflicts of interest.